

# THE MAGB HACCP PROTOCOL FOR MALTING

**Version 4**

**Release date March 2013**

**THE CONTROL VERSION OF THIS IS THE PDF COPY  
ON THE MAGB WEBSITE, ACCESSED AS  
[www.ukmalt.com](http://www.ukmalt.com)**

**THIS DOCUMENT IS MAGB INTELLECTUAL PROPERTY**



## REVISION HISTORY

This Guide was drawn up and finalised on September 2001, by an MAGB work group, whose members were:

Bruce Johnson	Pauls Malt Ltd
John Macdonald	Bass Brewers Ltd
Philip Morrall	Bairds Malt Ltd
Ivor Murrell	MAGB secretariat
Paul Randlesome	Crisp Malting Group Ltd
Steven Rowley	Simpsons Malt Ltd
Colin West	Muntons plc

The Guide was revised by an MAGB workgroup on October 1st 2002, whose members were:

Bruce Johnson	Greencore Malting Group
Hamish Bunker	Diageo Scotland Ltd
John Macdonald	Coors Brewers Ltd
Andrew Ness	Coors Brewers Ltd
Philip Morrall	Bairds Malt Ltd
Ken Steer Jones	Bairds Malt Ltd
Ivor Murrell	MAGB secretariat
Steven Rowley	Simpsons Malt Ltd
Peter Robson	Muntons plc
Denise Baxter	BRI

The Protocol was revised again by an MAGB workgroup on January 26th 2005, whose members were:

Bruce Johnson	Greencore Malt
Chris Scott	Crisp Malting Group
Paul Randlesome	Crisp Malting Group
Andrew Ness	Coors Brewers Ltd
Steve Rowley	Simpsons Malt Ltd
Vic Cameron	Diageo Scotland Ltd
Richard Broadbent	Bairds Malt Ltd
Nigel Davies	Muntons plc
Steve Click	Thomas Fawcett & Sons Ltd
Philip Morrall	Independent consultant
Ivor Murrell	MAGB Secretariat

The Protocol was revised by an MAGB workgroup on March 8th 2012, whose members were:

Bruce Johnson	Crisp Malting Group
Tiago Cabral	Molson Coors Brewing Company Ltd
Peter Longmate	Simpsons Malt Ltd
Alan Brown	Bairds Malt Ltd

Brian Topham	Boortmalt
Nigel Davies	Muntons plc
Brian Hickman	Thomas Fawcett & Sons Ltd
Colin West	MAGB Secretariat

A further revision and draft was prepared in December 2012 by Bruce Johnson of Crisp Malting Group for consideration on the 22<sup>nd</sup> January 2013 by the MAGB HACCP Workgroup, whose members included:

Bruce Johnson	Crisp Malting Group
Tiago Cabral	Molson Coors Brewing Company Ltd
Peter Longmate	Simpsons Malt Ltd
Alan Brown	Bairds Malt Ltd
Brian Topham	Boortmalt
Nigel Davies	Muntons plc
Brian Hickman	Thomas Fawcett & Sons Ltd
Colin West	MAGB Secretariat

# Table of Contents

<b>Part 1</b> .....	<b>4</b>
Introduction.....	4
Pre-Requisite Programs.....	8
<b>Part 2</b> .....	<b>23</b>
HACCP Protocol .....	23
Structure of HACCP System .....	25
Decision Tree .....	29
HACCP Protocol Applied to Malting .....	30
Classification of Hazards.....	31
Flow Chart Malt .....	32
Malt Hazard and Risk Ratings .....	33
Malt Critical Control Points (CCPs) .....	41
Flow Chart Co-Products.....	43
Co-Products Hazard and Risk Ratings.....	44
Flow Chart Specialist Malts .....	46
Specialist Malts Hazards and Risk Ratings .....	47
Critical Action Plan Specialist Malts.....	51
Heat related toxins guidelines.....	53
Allergenic Reactions Information .....	54
END .....	54

# THE MAGB HACCP PROTOCOL FOR MALTING

---

## PART ONE

### 1. INTRODUCTION

#### 1.1. Background and purpose.

This national document has been drawn up at the request of MAGB members, and by a work group of industry experts from several malting companies, appointed by the MAGB Technical Committee. The Protocol carries no legal force, and its use is voluntary.

UK malting companies had each drawn up HACCP assessments for their malting sites, and their individual procedures have been in place for several years. In recent years customers have been auditing supplier product safety schemes, and maltsters have felt that the provision of an industry Protocol to the essential core elements of malting HACCP will underline their commitment to food and product safety.

It is intended that the pooling of expert knowledge of what can form a potential hazard in malt production and dispatch, and how it can be avoided, or detected, will ensure that an industry standard of good practice will be maintained.

#### 1.2. Regulatory framework.

Directive 93/43/EEC of 14 June 1993 stipulates in Article 3 “food business operators shall identify any step in their activities which is critical to ensure food safety and ensure that adequate safety procedures are identified, implemented, maintained and reviewed on the basis of the principles used to develop the system of HACCP (Hazard Analysis and Critical Control Point)”. It should be noted that all maltings are classified as Food Businesses and should be registered as such, under the requirements of national legislation.

This HACCP Protocol closely adheres to the Codex Alimentarius Food Hygiene requirements as published by the Joint FAO/WHO Food Standards Programme (CAC/RP 1-1969, Rev 3 (1997), amended 1999). As such, this HACCP Protocol describes how to establish a suitable HACCP team and evaluate the production process according to the essential HACCP principles, to ensure appropriate food hygiene standards.

#### 1.3. Requirement of a business management system

A business management system must be in place for the company, which is structured to underwrite compliance with Parts 1 and 2 of this HACCP Protocol, and provide evidence that the prerequisite requirements and critical control points are

under control.

#### **1.4. The scope of the MAGB HACCP Protocol is for malt and co-product manufacture**

This Protocol applies to the industrial production of barley malt from the intake and storage of barley for supply as malt to breweries and distilleries and food industries, and the malting co-products produce by those operations.

The term 'malt' includes ale, lager and distilling malts (white malt) and also speciality malts (such as crystal and roasted malt) as well as unmalted roasted cereals.

It deals with operations from the intake of raw materials to the loading of malt at the maltings. It also covers the production of cereal co-products of the malting process, for supply as animal feeding materials. The risks considered are only those that relate to consumer and animal health. Factors that may affect product sensory or other attributes are not considered where they are not linked to food safety.

The purpose of this Protocol is to assist in the identification of biological, chemical and physical hazards that could occur in malting raw materials, malting processes and environments, which may cause the end product to be unsafe for human or animal consumption, as appropriate.

It will identify critical points in the malt and co-product manufacture process where control can be applied to prevent, eliminate or reduce hazards to acceptable levels. The preventative measures to be implemented at these critical points are also identified.

It is intended that the Protocol should provide an auditing framework for the industry.

The Protocol is written for the production of white malts and peated malts, with separate Annexes for variation in techniques for roasted and specialist malts.

It should be noted that all maltings co-products, intended for animal feed either, as direct feed or as compound ingredients should comply with all the requirements of the Feedingstuffs legislation. This Protocol is intended to assist compliance with that obligation.

Members of the team drawing up this Protocol were also involved with the production of the Euromalt EU HACCP guide for malting. The EU Guide is effectively a policy document, which has a restricted field of application, in terms of the scope of the operation, in sympathy with national practices. The MAGB Protocol meets all the requirements of the Euromalt EU HACCP Guide for malting, but deals with malt and co-product manufactured from the intake of raw grain from farm, and gives

specific control data.

### **1.5. Malt and co-product manufacture - Overview of the malting process**

Malt is made from malting grade barley, by soaking it in water, and then allowing germination to take place under carefully controlled conditions. This first stage of the process is very similar to what occurs in nature when the grain is sown in the earth. However, when the changes inside the grain are to the maltsters' requirements, then the final stage in the malting process is the application of heat in a specially designed kiln, and the resultant product, malt, has a moisture content of below 6.5%. The kilning process imparts flavour and colour into the malted grain, and the low moisture content allows safe storage. The final malt superficially resembles the original barley in outward appearance, but is physically and bio-chemically much changed.

Malt intended for distilling use may have peat smoke introduced into the airflow through the malt kiln, to give the particular characteristics needed by the spirit to be made from it.

Coloured or roasted malts will have different heat application than white or peated malts.

The raw material for co-products is barley, in a raw and processed (i.e. malted) form. The co-products are separated from the barley and malt, as appropriate, at a number of processing stages using aspiration and screening.

The material collected is stored prior to dispatch and/or further processing into a pelletised form.

### **1.6. Intended use of malt and co-products**

Malt is used predominantly as the basic raw material for beer and spirit, with a much smaller quantity used in the food industry, (e.g. bread, biscuits, breakfast cereals and bedtime drinks.)

There are four product groups:

White malts.

Peated malts.

Coloured and speciality malts/ roasted malts

Roasted barley.

Malt is used predominantly as the basic raw material for beer and spirit. Some malt is also used in the manufacture of grain spirit. Brewing and distilling operations involve further processing, both of which include heating and filtration steps that will sterilise and filter the process stream. There is also a significant dilution effect (about 7 to 10 fold).

1.6.1.Co –products suitable for feeding animals are produced at various stages in the malting operations.

At the intake of raw grain, a sieving process removes all the cereal matter that is not suitable for malting, this includes:

Barley dust and very small particle matter, this is produced every time grain is moved.

Small corns

Grain husk, awn and other harvest debris

This material is termed co-product and all can be used for animal feed

During the malting process short roots are produced on the germinating corn, these wither during the kilning process and can be easily mechanical removed from the finished malt. The resultant material is called malt culm, and has higher protein content than the original barley in dry weight terms, so is a useful animal feed.

Every time malt is moved, gentle abrasion of the corns of malt produces malt dust, which can also be incorporated into animal feed.

Some sites may produce a pelletised feed co-product, from combinations of some of the materials produced by grain movement and the malting operations as indicated in 1.6.2.

1.6.2.Malting is considered a low risk process, involving grain, water, heat and airflow. Malt and its co-products have a long history as products that have not caused harm to the end consumer. However, malt and its co-products are not sterile commodities. Potential hazards, which could affect consumer health, have been identified. These include product contamination, mycotoxins in raw grain, pesticides, nitrosamines and chloropropanols in highly coloured malts. General preventative measures can greatly reduce risk, and such measures include:

Good malt and co-product manufacturing practices.

The use of a formalised quality management system, with defined working procedures.

Suitably trained personnel.

Traceability of product from intake barley truck, through bulk to final customer delivery.

## **1.7. Definitions of terms.**

A definition of all terms used in this Protocol is listed in Part 2 Section 1.3.



## **1.8. Layout of this Protocol**

This Protocol is in two parts:

Part 1 Introduction and general principles of good malt and co-product manufacture practice, which contribute to assurance of product quality and safety via the application of Pre-Requisite Programs (PRP).

Part 2 The HACCP section, and the identification of critical control points for a typical UK malting site.

## **1.9. Exclusions**

### **1.9.1. Construction materials**

It is assumed that all construction materials used in a maltings, and in contact with product are fit for purpose.

### **1.9.2. Energy Utilities**

These are outside the scope of this guidance note.

## **1.10. Remedial Action**

This Protocol gives an indication of remedial action to be taken in the event of critical limits on a Critical Control Point being exceeded. Individual malting company HACCP and quality assurance systems will deal with the detail of remedial action.

## **2. GENERAL PRINCIPLES OF GOOD MALT AND CO-PRODUCT MANUFACTURE PRACTICE: PRE-REQUISITE PROGRAMS**

Definitions:

‘Prerequisite Programs’ - The measures that provide the appropriate environmental and operating conditions in a food operation that are necessary for the preparation of safe and wholesome food.

‘Operational Prerequisite Programs’ - The measures, related to a specific process step/stage, that provide the appropriate environmental and operating conditions in a food operation that are necessary for the preparation of safe and wholesome food.

The decision tree (below) may be used to help define and distinguish such prerequisite programs. It is included here for guidance only.

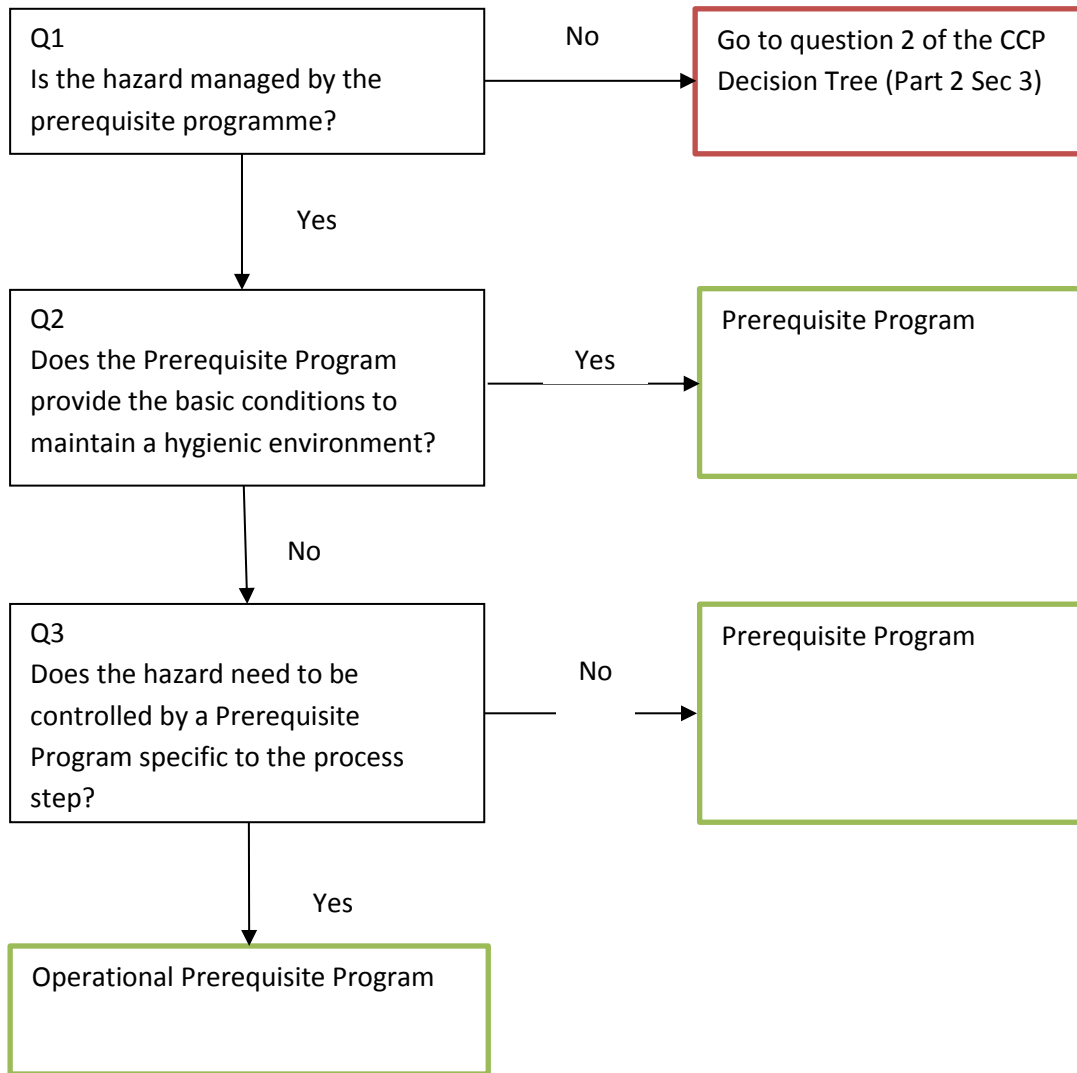

## 2.1. Establishment - Premises: Design and Facilities

PREREQUISITE PROGRAMS			
Prerequisite Program (PRP)	Hazard(s) Controlled by the PRP	Checking Procedures	Remedial Actions
<b>1.Premises</b> The establishment should be located, constructed, and maintained according to sanitary design principles (see 2.1.1).	Hygiene related food safety risks and product contamination.	The active involvement of the HACCP team in any design, project and engineering work being undertaken on site.	Take appropriate action to remedy any adverse food safety risk.

<p><b>2.Maintenance</b> Preventive maintenance program should be in place (see 2.1.2).</p>	<p>Hygiene related food safety risks and product contamination.</p>	<p>Compliance with preventive maintenance program</p>	<p>Review effectiveness of the program and take appropriate action to remedy any defects or deficiencies.</p>
<p><b>3.Glass policy</b> Glass is covered or guarded to prevent contamination of product. Glass breakage procedures are in place (see 2.1.3).</p>	<p>Introduction of glass or brittle plastic from equipment and the environment.</p>	<p>Scheduled inspection at an appropriate frequency of registered glass and brittle plastic fittings.</p>	<p>Take appropriate action to remedy any defects. Record actions taken.</p>
<p><b>4.Equipment</b> Ensure equipment is calibrated at defined frequency against traceable standards (see 2.1.4).</p>	<p>Hygiene related food safety risks and product contamination related to equipment being out of calibration.</p>	<p>Adhere to calibration schedule and standards.</p>	<p>Review effectiveness of the program and take appropriate action to remedy any defects or deficiencies.</p>
<p><b>5.Hygiene</b> Good standards of housekeeping and cleanliness must be maintained. A fully documented system of process plant cleaning should be in place (see 2.1.6).</p>	<p>Introduction of biochemical, microbiological and chemical hazards to the product.</p>	<p>Adhere to hygiene schedule and standards.</p>	<p>Review effectiveness of the program and take appropriate action to remedy any defects or deficiencies.</p>
<p><b>6.Cleaning Materials</b> Cleaning and disinfection products must conform to any national legislation and be fit for purpose (see 2.1.7).</p>	<p>Cleaning material residues in product.</p>	<p>Follow manufacturer's instructions and ensure sufficient rinsing of agents.</p>	<p>Review effectiveness of the cleaning materials and the cleaning regimes. Record actions taken.</p>
<p><b>7.Lubrication Materials</b> Use food grade lubrication where possible.</p>	<p>Lubrication material residues in product.</p>	<p>Check the specification of the lubricants being used.</p>	<p>Review effectiveness and specification of the lubricants used. Record actions taken.</p>

<b>8.Pest Control</b> An effective pest control system must be in place (see 2.1.8).	Pest ingress and contamination of the product and infrastructure.	Structured monitoring program supported by records.	Review effectiveness of the pest control program and any actions/treatments authorised. Record actions taken.
<b>OPERATIONAL PREREQUISITE PROGRAMS</b>			
<b>Operational Prerequisite Program (OPRP)</b>	<b>Hazard(s) Controlled by the OPRP</b>	<b>Checking Procedures</b>	<b>Remedial Actions</b>
<b>9.Magnets</b> Magnets to be located at key product process steps (see 2.1.5)	Introduction of metal to the product.	Adhere to magnet checking and cleaning regime.	Review effectiveness of the magnets and record any actions taken.

Further information referenced from the above table:-

#### 2.1.1.Location

The site must conform to any national legislation that specifies minimum distances from other facilities.

#### 2.1.2.Premises

Buildings should be fit for their purpose, adequately maintained and designed so as to be easy to clean and minimise risks of contamination.

Good standards of cleanliness should be maintained across the site and adequate sanitary facilities should be available for staff and conform to any national legislation.

#### 2.1.3.Glass and Brittle Plastic

Where possible glass or brittle plastics should not be used in construction or operation in production areas. Where this is unavoidable protection should be in place in case of breakage.

Every malting site should have a documented glass policy, which stipulates where glass or brittle plastic may not be used or taken into the plant. The possibility of contamination should be reduced by the use of safety bulbs or tight covers wherever possible.

Any glass or brittle plastic sited in the plant in an area that could contaminate product should be detailed in a Glass Register, which should be reviewed and

updated regularly. The glass policy should include an audit frequency. Procedures for action on the discovery of broken glass should be documented, and staff trained to be aware of these procedures.

#### 2.1.4. Equipment

All construction materials and machinery used in the maltings and in contact with the product should be fit for the purpose.

Surfaces in processing areas should be easy to clean and resistant to abrasion.

Equipment should be regularly maintained, calibrated (where appropriate) and records kept.

#### 2.1.5. Removal of Metal

Magnets and/or metal detectors should be positioned in barley, malt and co-product flows to remove any metal objects that find their way into the process line.

Magnets should be cleaned on a regular basis, and the action documented and evaluated.

Magnets should be inspected regularly and records maintained of debris found.

#### 2.1.6. Cleaning

Good standards of housekeeping and cleanliness must be maintained. A fully documented system of process plant cleaning should be in place.

##### SILOS

Empty silos should be swept or vacuumed to the sites cleaning schedule to remove grain residues, and may be fumigated or treated with suitable insecticides according to company policy.

Only chemicals that conform to national legislation and are approved by the malting and brewing industry should be used.

Operators using pesticides should be trained and registered according to national legislation.

Records of chemical applications should be kept.

#### 2.1.7. Cleaning Materials

Cleaning and disinfection products must conform to any national legislation.

They should be clearly labelled and stored appropriately, where there is no

danger of them contaminating raw materials, process streams or finished product.

Empty containers should not be re-used for other purposes.

Records should be kept of the chemicals on site, together with relevant safety data sheets, as required under COSHH, together with risk assessments for storage and use.

#### 2.1.8. Pest Control

A pest control programme should be in place.

##### **ON SITE**

A suitably qualified pest control specialist (Approved according to any national legislation) should be appointed to control pests in all critical process, production and storage areas.

Areas which should be addressed include materials used, infestation due to intake of materials, ingress of pests, waste accumulation and disposal, frequency of treatment and inspection and evaluation of pest control performance.

Records should be kept of all treatments and inspections.

All storage, process, packaging and dispatch areas should be protected against bird ingress. Doors and hatches etc. should be kept closed when not in use.

Waste materials that might encourage pests should be regularly cleared away and disposed of.

Pest control performance should be evaluated on a determined time scale.

##### **GRAIN IN STORE**

All personnel involved applying insecticides should be appropriately trained, in accordance with any national legislation. Records of all training should be kept.

Insecticides or fumigants applied to grain, to stores or to equipment should be approved under national legislation and only BBPA approved agrochemicals are recognised as acceptable by the malting and brewing industries for the use intended.

The dose applied should be controlled, and conform to national and industry limits. Records should be kept, to include, the chemical used, the dose and date of application and the person involved.

All agrochemicals should be clearly labelled and should not be transferred to alternative packages. They should be stored in a secure place away from the production areas. Empty packages should not be reused for other materials.

Records should be kept of all agrochemicals on site.

Spraying equipment should be regularly maintained and calibrated. Records should be kept.

## 2.2. Establishment - Personnel

<b>PREREQUISITE PROGRAMS</b>			
<b>Prerequisite Program (PRP)</b>	<b>Hazard(s) Controlled by the PRP</b>	<b>Checking Procedures</b>	<b>Remedial Actions</b>
<b>1. Personnel Hygiene</b> Personnel working on the site should comply with any national guidelines for food handlers concerning fitness to work (see 2.2.1).	Hygiene food safety risks and product contamination related to employees	Adhere to hygiene policy and standards.	Take appropriate action to remedy any defects or contamination. Record actions taken.
<b>2. Visitors &amp; Contractors</b> Ensure visitors and contractors are controlled whilst on site (see 2.3.2)	Hygiene food safety risks and product contamination related to non-employees	Adhere to hygiene policy and standards. A formal visitor reception procedure should be used, with controlled access to site and induction with basis food safety rules.	Remove and ban from site visitors and contractors who fail to comply with Company rules.
<b>3. Eating &amp; Drinking</b> If allowed, these activities should only take place in designated areas (see 2.2.3)	Hygiene food safety risks and product contamination.	Adhere to hygiene policy and standards.	Take appropriate action to remedy any defects or contamination. Record actions taken.

<p><b>4.Jewellery Policy</b> Employees, contractors and visitors to comply with jewellery policy (see 2.2.4).</p>	<p>Physical contamination of product.</p>	<p>Adhere to jewellery policy and standards.</p>	<p>Take appropriate action to remedy any defects or contamination. Record actions taken.</p>
<p><b>5.Training</b> Personnel are trained, instructed and supervised relating to their activity and are competent to undertake the tasks required. Where staff is engaged in activities related to OPRPs and CCPs, specific training is given (see 2.2.5).</p>	<p>Introduction of hazards due to failure to follow correct policies, procedures and work instructions.</p>	<p>Scheduled review (at appropriate frequency) of staff competence to perform activities.</p>	<p>Review training needs. Record actions taken.</p>

Further information referenced from the above table:-

**2.2.1.Health status**

Personnel working on the site should comply with any national guidelines for food handlers concerning fitness to work.

**2.2.2.Visitors**

A formal visitor reception procedure should be used, with controlled access to site and induction with basis food safety rules.

**2.2.3.Eating, drinking and smoking**

If allowed, these activities should only take place in designated areas.

**2.2.4.Jewellery and loose items policy**

The site should have a written procedure stipulating what jewellery, mobile phones, pens etc, if any, can be worn on site, and what action is to be taken if anything is lost in a process area.

**2.2.5.Training**

Personnel should be adequately trained for the tasks they are carrying out. This will include general food hygiene and safety, HACCP and FEMAS awareness.

Operators involved with the application of pesticides should have appropriate training, according to national requirement.



Records of training, either completed or planned should be kept.

### 2.3. Control of Operations – Raw Materials & Products

<b>PREREQUISITE PROGRAMS</b>			
<b>Prerequisite Program (PRP)</b>	<b>Hazard(s) Controlled by the PRP</b>	<b>Checking Procedures</b>	<b>Remedial Actions</b>
<p><b>1. Water</b> Water used in the production of malt and co-products must comply with the appropriate EU and national water quality legislation (see 2.3.3).</p>	<p>Introduction of biochemical, microbiological and chemical hazards to the product.</p>	<p>Monitor water quality.</p>	<p>Review effectiveness of the monitoring program and of any on site water treatment. Record actions taken.</p>
<p><b>2. Air</b> Air used in the production and processing of malt and co-products must be fit for purpose (see 2.3.5).</p>	<p>Contamination of the product.</p>	<p>Intakes for air used in processing should be sited so as to avoid sources of pollution such as vehicle exhausts.</p>	<p>Take appropriate action to remedy any defects. Record actions taken.</p>
<p><b>3. Due Diligence Program</b> A risk- evaluated monitoring program for raw materials and product to validate control activities (see 2.3.7).</p>	<p>Verification of controls for food safety of raw materials, products and co-products.</p>	<p>Compliance with agreed testing schedule and residue limits.</p>	<p>Take appropriate action to remedy any defects. Record actions taken.</p>
<p><b>4. Transport/Haulage</b> Use transport which complies with the AIC Code of Practice for Road Haulage in TASCC (Trade Assurance Scheme Combinable Crops) (see 2.3.10).</p>	<p>Possible physical, biological and chemical contamination of raw materials and product from unfit transport.</p>	<p>Use of approved haulier. Supplier audits and performance checks. Vehicle inspection.</p>	<p>Review and possible withdrawal of approved status from haulier. Agreed corrective action and rejection of load.</p>

<p><b>5. Processing Aids</b> All processing aids used must be suitable for food use, should be clearly labelled and stored securely and at the appropriate temperature (see 2.3.4)</p>	<p>Contamination of product through use of inappropriate grade of processing aid.</p>	<p>Check the specification of the processing aids being used.</p>	<p>Review effectiveness and specification of the processing aids used. Record actions taken.</p>
<p><b>OPERATIONAL PREREQUISITE PROGRAMS</b></p>			
<p><b>Operational Prerequisite Program (OPRP)</b></p>	<p><b>Hazard(s) Controlled by the OPRP</b></p>	<p><b>Checking Procedures</b></p>	<p><b>Remedial Actions</b></p>
<p><b>5.Intake of Stored Grain</b> Cereal must be sound and fit for purpose. Adoption of good storage practices allied with purchase conditions and intake procedures (see 2.3.2).</p>	<p>Mycotoxin contamination derived from active moulds.</p>	<p>Assured grain, assured transport, purchase conditions and intake procedures. Moisture content, look and smell.</p>	<p>Review and possible withdrawal of approved status from supplier. Agreed corrective action and rejection of load.</p>
<p><b>6.Intake of Stored Grain</b> Cereal must be sound and fit for purpose. The use of approved agrichemicals must be declared and managed according to BBPA regulation (see 2.3.1).</p>	<p>Contamination through use of non-approved pesticide, or excess application of agrochemical</p>	<p>Check passport. Ensure any pesticide declared meets BBPA approval for type.</p>	<p>Review and possible withdrawal of approved status from supplier. Rejection of load.</p>
<p><b>7.Malt and CoProduct Storage</b> Cereal must be sound and fit for purpose. Product storage conditions to be such to prevent microbiological spoilage (see 2.3.2 &amp; 2.3.8).</p>	<p>Mould growth leading to potential mycotoxin contamination.</p>	<p>Stock rotation and records. Malt storage moisture to be managed to avoid conditions for mycotoxin production.</p>	<p>Review grain condition. Record actions taken.</p>
<p><b>8.Malt Kilning</b> Kiln design and air quality managed to minimise risk of NDMA formation (see 2.3.5).</p>	<p>Formation of NDMA.</p>	<p>Indirect firing and low NOX burners to prevent NDMA formation. Control of air quality.</p>	<p>Scheduled analysis and review of data. Record actions taken.</p>

Further information referenced from the above table:-

### 2.3.1. Raw materials – cereals

Definition: 'Due Diligence' - Some contaminants may be only very infrequently encountered, very expensive to determine or are not uniformly distributed through a grain bulk. Frequent routine sampling becomes impractical. For several years the MAGB and its members have conducted ongoing surveys of barley and malt for various food safety analytes (e.g. heavy metals, mycotoxins). When the data is pooled the extent of the potential problems may be better determined and monitored. The data sets are updated regularly to ensure that there is no change to the likelihood or risk from potential hazards.

Assured grain. The UK malting industry has been encouraging growers to be members of an approved Assured Grain Scheme, which ensures that good farming practice, and grain storage/movement has been carried out to an agreed and auditable standard. Assured grain must be clearly declared as such, at delivery to the maltings. The cereal used for UK malt and associated co-product manufacture is mainly barley, which this Protocol concentrates on, although a very small amount of wheat is also malted. Deliveries should conform to the maltster's specifications, which will take into account the customers' requirements and any regulatory limits (for example for mycotoxins, pesticides and heavy metals).

Cereal raw material, if stored, must be managed in such a way as to minimise the risk from mycotoxins (see 2.3.2). Spot testing will be carried out by maltsters to ensure due diligence in this respect.

Careful inspection and evaluation of all deliveries of raw grain will remove a significant potential of introducing risk to product, and ensure the correct barley is accepted. Visual inspection must take place for insects, foreign material and mould. The smell of the barley before intake will reveal if it has been stored in good condition. Any taint or "nose" will result in rejection of the load.

An AIC Pesticide Passport must accompany every delivery of barley to a maltings, indicating whether or not a pesticide has been applied by the grower/seller post harvest. If pesticide has been applied the pesticide type and an assurance that good working practice has been followed must be declared. No delivery will be accepted without an accompanying passport, and grain will be refused if the pesticide does not comply with the maltster's specifications for malting barley purchases. Spot testing will be carried out by maltsters to ensure due diligence in this respect.

The maltster's terms of purchase for malting barley should state that the only agricultural chemicals that can be applied to malting barley during its growth,

harvest and storage are those that are named on the British Beer and Pubs Association (BBPA) approved agricultural chemicals list. This covers herbicides, fungicides, insecticides, growth regulators, etc. The BBPA approved list is updated at least once a year.

“Due diligence” testing will require sampling plans to be in place to check residues, (for example of pesticides, mycotoxins and heavy metals) for conformity to legal limits.

### 2.3.2.Storage of grain

Grain should be stored in sound, dedicated stores and protected from water ingress. For long-term storage, grain should be dried down as quickly as possible to moisture content of below 13% in order to ensure good germination characteristics (<13%) and to prevent grain spoilage from storage fungi (<14.5%), mites (<14.5%) and insects (temperature < 15deg C). All these recommended moisture figures, and in the paragraph below are based on a grain temperature of 15 degrees centigrade, unless stated otherwise.

Ochratoxin A is the main mycotoxin associated with badly stored damp grain. However, due diligence monitoring has proven that the risks and frequency of such a problem with UK malting barley bulks, although real, are quite small. The risk of Ochratoxin A is greater with wet harvest conditions, but drying barley to less than 18% moisture content prevents the storage fungus, *Penicillium verrucosum* from growing and from producing the toxin. ‘Green’ barley should not be stored for longer than 2 weeks over 18%. If the harvested barley is received at an elevated temperature of 20-25degC, this safe moisture limit can decrease by up to 0.5%. Given that temperature affects the equilibrium relative humidity (erh) of grain, cooling grain significantly reduces any moisture related spoilage risks.

Spot testing for Ochratoxin A will be carried out by maltsters to verify the management of grain in store.

Relevant Codes of practice for safe storage should be followed. The following documents provide good background information on best practice:

*HGCA The Grain Storage Guide Version 3 Autumn 2011*

*HGCA Topic Sheet No 60, Ensuring Good Germination in Malting Barley*

Evidence of temperature monitoring will be in place. The procedure will identify what actions limits for temperature will be operated.

### 2.3.3.Water

Water used in the production of malt and co-products must comply with the appropriate EU and national water quality legislation.

Storage tanks of process water should be covered and access should be regulated for security.

#### 2.3.4. Processing aids

All processing aids used must be suitable for food use, should be clearly labelled and stored securely and at the appropriate temperature. There should be written application protocols and methods of use should conform to any relevant legislation.

Customer specifications may permit, very small quantities of gibberellic acid to be applied during the process to enhance the modification of the grain.

It is also common for sulphur dioxide to be used in kilning to control the formation of nitrosamines.

Peat smoke, from burning peat may be introduced to the airflow through the kiln for the manufacture of malts for whisky distilling. This produces taste and aroma properties in the finished malt, to the customer's requirements

#### 2.3.5. Air

Intakes for air used in processing should be sited so as to avoid sources of pollution such as vehicle exhausts.

In certain circumstances ambient NO<sub>x</sub> in the air can combine with hordein in the malt during the kilning process to produce elevated nitrosamines levels. The high NO<sub>x</sub> levels in combustion gases can result in elevated nitrosamines levels in direct-fired kilns, especially where natural gas is the fuel source. Nitrosamines (NDMA) formation can be controlled by the introduction of sulphur dioxide into the airflow through the malt being kilned

Malt samples are regularly tested to ensure that delivered malt complies with the agreed maximum limit of 5 ppb of NDMA. (See 2.3.7)

#### 2.3.6. Process control

Process parameters such as temperature, time and moisture should be controlled within the limits required for the type of malt being made. Temperatures and moistures in excess of those required for modification should be avoided in order to limit the opportunity for mould growth.

#### 2.3.7. Due diligence testing on malt and barley

MAGB members randomly test their barley for pesticide residues and mycotoxin, on a risk- evaluated basis, and valid sampling plans for control activities are defined and managed in accordance with BS 6001-1:1999 and BS 6002-4.1:1996, as appropriate) and in accordance with the MAGB

recommended sampling schedules. The industry's analyses results are collated by the MAGB on an annual basis, to show due diligence. (See 2.3.1 and 2.3.2)

NDMA test results on delivered malts are also collated by MAGB for each crop year, to record due diligence. (See 2.3.5)

The MAGB arranges for a survey to be carried out every year on the barley crop, and malt produced from that crop year. The survey covers a wide range of food safety checks, including heavy metals and mycotoxins analyses, and any substances that are deemed pertinent. . Its surveys to date show that both UK barley and malt are well below the maximum levels set by legislation for heavy metals.

#### 2.3.8. Malt Storage

Malt should be stored in sound, dedicated stores and protected from moisture uptake.

#### 2.3.9. Packaging

Any packaging materials (e.g. plastic sacks or liners) should be suitable for food use and conform to any relevant EU legislation. They should be stored in a clean, dry place and protected against infestation.

#### 2.3.10. Transport

Grain transport - Transport of the grain from the farm to the maltings is a potential source of contamination, but to prevent this problem, maltsters require that vehicles comply with the AIC Code of Practice for Road Haulage. This specifies the need to clean trailers out thoroughly between loads, and details products that cannot be transported in vehicles that haul grain for food use.

Co-products - The food safety requirements for the transport of grain into maltings equally apply for co-products from the maltings, for use as animal feed into the food chain.

Malt transport - As a minimum complies with the AIC Code of Practice for Road Haulage in TASCC (Trade Assurance Scheme Combinable Crops).

### 2.4. Validation, Verification Auditing and Review.

#### 2.4.1. Validation

Within each company, the person with nominated responsibility for HACCP will review, at least annually, HACCP schemes and associated procedures to ensure that the systems are appropriate and effective.

The nominated person will monitor legislation and monitor new plant and product development to ensure that any new hazards are fully evaluated and

controlled using the documented HACCP scheme.

Any customer complaint involving a food or feed safety issue will be fully investigated to determine if the HACCP scheme and procedures are at fault or not and are being complied with.

#### 2.4.2.Verification

This will involve regular documented audits by companies.

Nominated members of the company HACCP team will conduct regular documented HACCP site and local audits. This will involve a physical inspection of plant and a review of records and documents relating to HACCP.

Non-conformances and corrective actions will be recorded.

# THE MAGB HACCP PROTOCOL FOR MALTING

---

## PART TWO

### 1. HACCP SCHEME PROTOCOL.

#### 1.1. The CODEX HACCP approach to managing food safety risk

HACCP (Hazard Analysis by Critical Control Points) is a system that allows identification and control of risks to food safety in a process. It involves identification of the potential hazards (of biological, chemical or physical nature), evaluation and prioritisation of risks and installation of systems by which those risks are monitored and controlled.

The protocol of HACCP, as defined

- i) Conduct hazard analysis.
- ii) Determine critical control points.
- iii) Establish control limits.
- iv) Devise a system to monitor control.
- v) Establish corrective action.
- vi) Procedures for verification (that the system is working.)
- vii) System documentation needed to support all the above.

The operation of a HACCP system is detailed in Part 2 Section 2.,

#### 1.2. Prerequisite Programmes and Critical Control Points

Prerequisite Programmes (PRPs) must be developed, documented and implemented in order to control factors that may not be directly related to manufacturing (malt and co-product manufacture) controls, but which support the HACCP plan. PRPs generally deal with generic or "site-wide" issues and often reflect controls applied to raw materials earlier in the supply chain.

The prerequisite programmes for malt and co-product manufacture are outlined in part 1, section 2, of this Protocol, and cover the environment (premises and personnel) and product (including raw material). Given their importance, a number of PRPs have been highlighted in the HACCP Scheme Protocol (part 2) and are included in the appropriate tables (from section 7).

In contrast, Critical Control Points (CCPs) are steps in the production process where control is applied to eliminate a particular hazard, or to reduce it to an acceptable level. Decision Trees (see section 3 for an example) can prove useful in the identification of CCPs by giving structure to the consideration, in turn, of each



hazard at each process stage. Each CCP is assigned a critical control limit.

### **1.3. Terms used**

#### **Hazard**

A biological, chemical or physical impact on the production of malt, which may cause the finished product to be unsafe for human consumption, or for animals intended for the human food chain.

#### **Risk**

The likelihood that a hazard will occur.

#### **Preventative measures**

Actions that can be taken, or factors that can control an identified hazard.

#### **Critical Control Point (CCP)**

A point, step or procedure in the malt and co-product manufacture process where control can be applied to prevent, eliminate or reduce a hazard to an acceptable level. Conversely, lack of control could result in the increased development of a hazard.

#### **Prerequisite Programs (PRP)**

The measures that provide the basic environmental and operating conditions in a food operation that is necessary for the production of safe and wholesome food.

#### **Operational Prerequisite Programs (OPRP)**

The measures that provide process specific environmental and operating conditions in a food operation necessary for the production of safe and wholesome food.

#### **CCP decision tree**

The formalised protocol for assessing an identified hazard at each process step (see section 3)

#### **Critical Limits**

Control limits (if measurable) that must be met for each preventative control in use at a CCP. They define the difference between safe and unsafe products.

#### **Corrective action**

Procedures to be followed when deviation from the critical limits occurs, that is when the process or product goes out of control at a critical control point.

#### **Monitoring**

Planned, recorded observations or measurements to assess if the process or product is under control.

#### **Audit**

A cross check of all or part of the HACCP systems effectiveness, at a minimum of twice per year.

### **Flow Chart**

A map showing the malt and co-product manufacture process from raw material intake to final product dispatch. (See section 6)

## **1.4. Potential Hazards**

Hazards fall into three categories:

**BIOLOGICAL CONTAMINATION** Coded (B) in this Protocol  
By organic materials present (e.g. animal/bird/insect remains), or from toxins produced from moulds and bacteria. Human contact with the product can cause bacterial contamination.

**CHEMICAL AND BIOCHEMICAL CONTAMINATION** Coded (C) in this Protocol  
By chemicals introduced deliberately (e.g. pesticides), by accident (e.g. fuel), cleaning chemicals, or actually produced by the malt and co-product manufacture process (e.g. NDMA) and from biochemicals such as toxins produced by moulds and fungi.

**PHYSICAL CONTAMINATION** Coded (P) in this Protocol  
By physical objects present in the raw barley (e.g. stones, glass, metal), or picked up from the malting plant (e.g. metal components, glass), or accidentally dropped in by process operator/contractors (e.g. pens/tools). In the event of a nuclear catastrophe, cereals sourced in the outfall area could be radioactive.

## **2. THE STRUCTURE OF A HACCP SYSTEM**

### **2.1. The twelve steps laid down in the CODEX protocol for HACCP (plus 2 others) have been used as the basis for the MAGB Protocol to HACCP in Malting.**

#### 2.1.1. Assemble a HACCP team

This should be multi-disciplinary and where possible include representatives from production, engineering, management, quality assurance and analytical. The team must include a person suitably qualified in HACCP procedures.

#### 2.1.2. Define the terms of reference and scope of study for the HACCP team

#### 2.1.3. Describe product

#### 2.1.4. Identify intended use

#### 2.1.5. Construct a process flow diagram

#### 2.1.6. Obtain on-site confirmation of flow diagram

2.1.7. List all potential hazards, conduct a hazard analysis, determine a relative risk for each hazard, and establish critical control points for each CCP

2.1.8. Determine CCP's

2.1.9. Establish critical limits for each CCP

2.1.10. Establish monitoring system for each CCP

2.1.11. Establish corrective actions

2.1.12. Establish verification procedures

2.1.13. Establish validation procedures

2.1.14. Establish documentation and record keeping

## 2.2. Using a HACCP system to identify and manage risks in malt production

2.2.1. A generic flow chart of the operations taking place at a maltings is illustrated in section 6. The flow should be confirmed as appropriate for individual sites and amended if required. A co-products and speciality malts flow chart is in Section 9.

2.2.2. Potential hazards to the consumer of the end product have been identified and considered, in turn, for each process step. Control measures are given for all hazards (see sections 8). Due consideration has been given to the risk of sabotage.

This Protocol lists the types of hazard at section 7 for malting and section 10 for co-products, categorised as biological, chemical and biochemical and physical.

2.2.3. The hazards have been analysed by using a scale number for the impact of the risk, and another for the likelihood of its occurrence, and multiplying one by the other.

**Risk rating = Impact X Likelihood.** (See section 7)

The rating system is tabulated below:

Impact rating	Likely effect
1	Consumption of the hazard might cause consumer distaste, but will not have any adverse physical health effect
2	Consumption of the hazard might cause mild adverse physical

	health effect if the consumer was exposed to the hazard over a long period of time
3	Consumption of the hazard might cause severe physical health problems (possible hospitalisation/death) in some /all people

Likelihood rating	Likely effect of no control being in operation
1	The hazard is present intermittently and if control of the product was absent at this point the hazard would be present in only part of one batch of product
2	The hazard is present intermittently and if control of the product was absent at this point the hazard would be present in the whole of one batch of product
3	The hazard is present continuously and if control of the product were absent at this point the hazard would affect several batches of product

2.2.4. The expert committee risk evaluated all hazards noted in this Protocol and submitted those significant hazards (scores 3 and above) to the CCP decision tree. The 'Decision Tree' (see section 3) was used to identify where hazards are eliminated or reduced to an acceptable level. The nodes of operation defined in this manner are termed the Critical Control Points or Prerequisite Programs and are indicated in section 8.

2.2.5. Critical limits for each CCP have been set, taking into account the degree of risk, the degree/severity of hazard and the likelihood of its occurrence (see section 8).

2.2.6. Where CCP's have been identified a system of monitoring is outlined in section 8, together with the relevant critical limits for that system of monitoring.

Similarly, corrective action for each CCP is outlined in section 9 in cases where deviations occur (as indicated by the monitoring system), such that the CCP is brought under control. Corrective action at site level will be as detailed by the Company for their site.

2.2.7. Verification of all controls identified, and CCPs in particular, will be carried out. The frequency of verification audits must be documented and recorded. Verification will examine all the written procedures to ensure that they are being carried out accordingly or issue a non-conformance and follow up action.

2.2.8.Co-products are handled as indicated by a generic flow chart in section 9, and the hazard analysis for co-products are shown in section 10.

2.2.9.Specialist malts are dealt with from Section 11.

### 3. THE DECISION TREE

To use this protocol, answer each question in sequence at each process stage, for each significant hazard identified (risk scores of 3 and above).

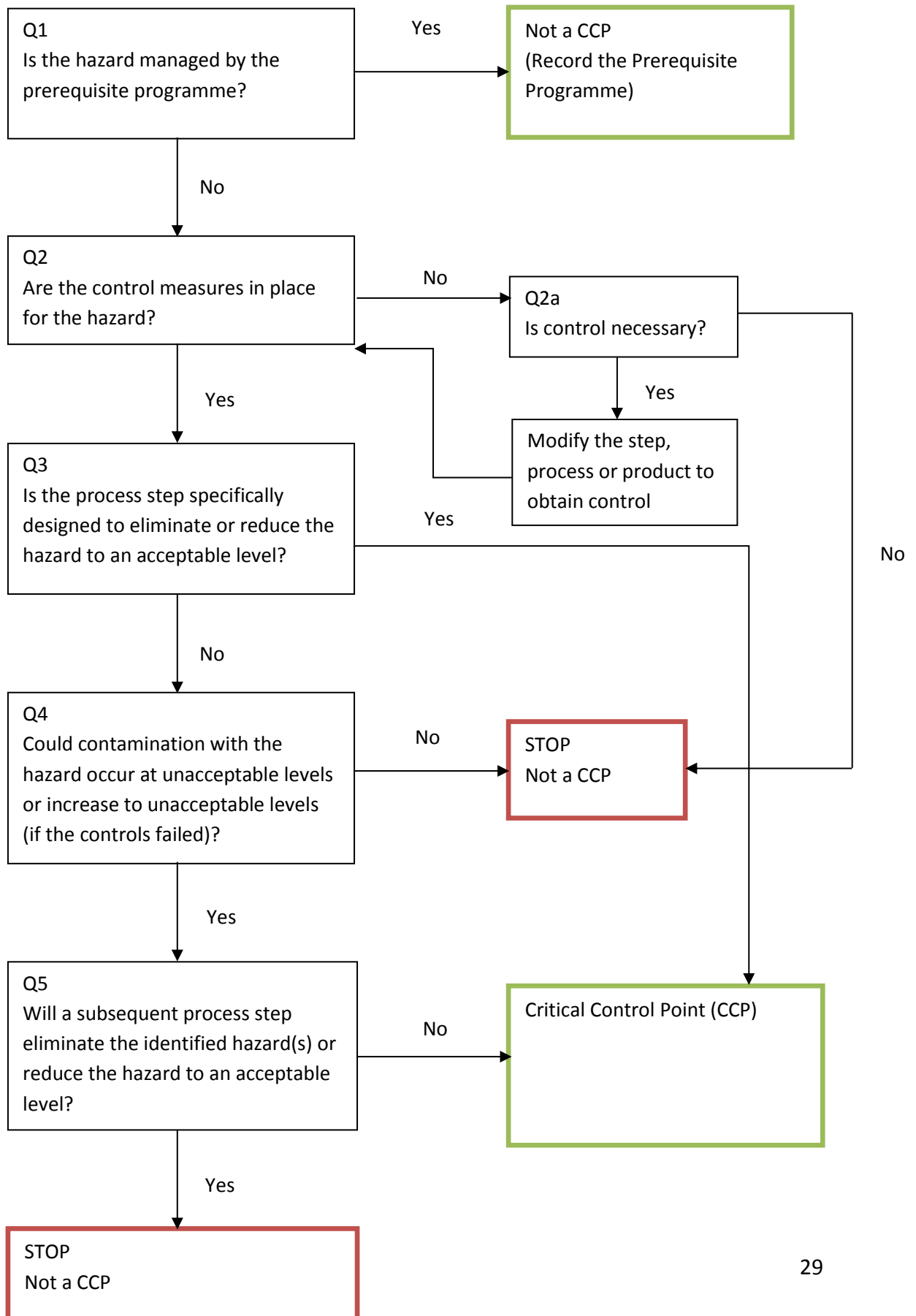

#### 4. THE HACCP PROTOCOL APPLIED TO MALTING

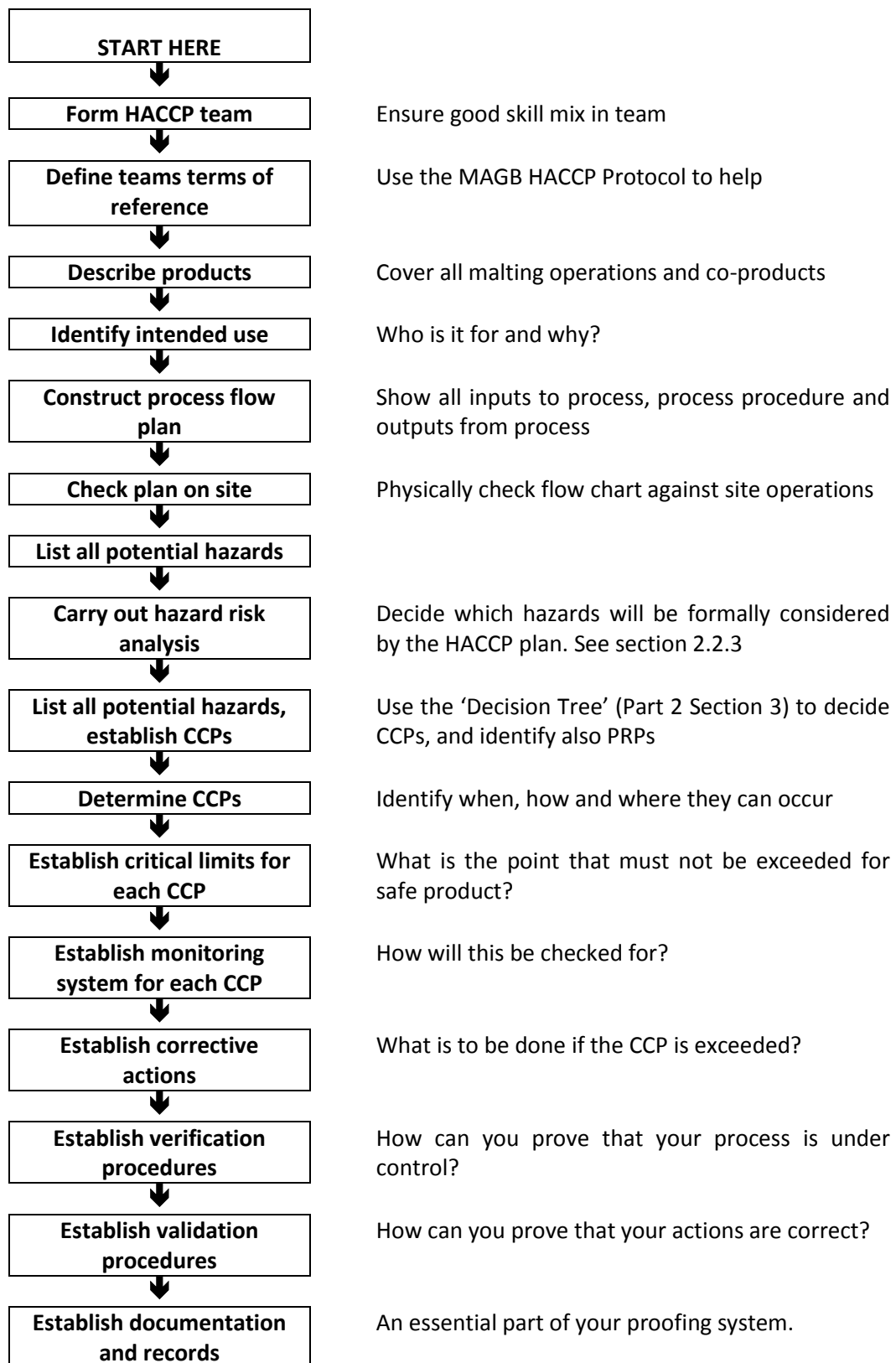

## 5. CLASSIFICATION OF POTENTIAL MALT AND CO-PRODUCT MANUFACTURE HAZARDS

HACCP experts in the industry have identified these listed hazards. An indication of the potential risk that they pose following the hazard risk analysis and the results of the application of the decision tree to the significant hazards (ie determining either management and control via PRP or CCP) is detailed in Part Two Section 7 of this Protocol.

HAZARD TYPE	HAZARD	CODE
BIOLOGICAL	Microbiological: (including human contact) Bacterial pathogens (e.g. E.coli, salmonella)	B1
	Microbiological: Fungi, and mould (e.g. Aspergillus, Penicillium, Ergot etc)	B2
	Insects, birds, rodents	B3
CHEMICAL	Mycotoxins (e.g. Ochratoxin A)	C1
	Nitrosamines (e.g. NDMA)	C2
	Pest control residues (e.g. insecticides, rodenticides.)	C3
	Agricultural control residues, (e.g. herbicides, fungicides, growth regulators)	C4
	Glycosidic Nitriles (only in distilling)	C5
	Heavy metals, nitrates/nitrites, PCB's	C6
	Thermal transfer fluid, hydraulic oil, lubrication and fuel oil	C7
	3-Monochloropropanediol and/or acrylamide(only in high colour malts and roasted barley)	C8
	Cleaning chemicals or water treatment chemicals	C9
	Taint or odours from other than those listed above	C10
	Allergens (See BRi note on Allergens in the section 15)	C11
PHYSICAL	Contamination by metal objects	P1
	Contamination by non metal objects (e.g. other seeds, cereals etc)	P2
	Contamination by radioactivity	P3



**6. FLOW CHART MALT MANUFACTURE (process stage numbers link to Ref in Sec 7)**

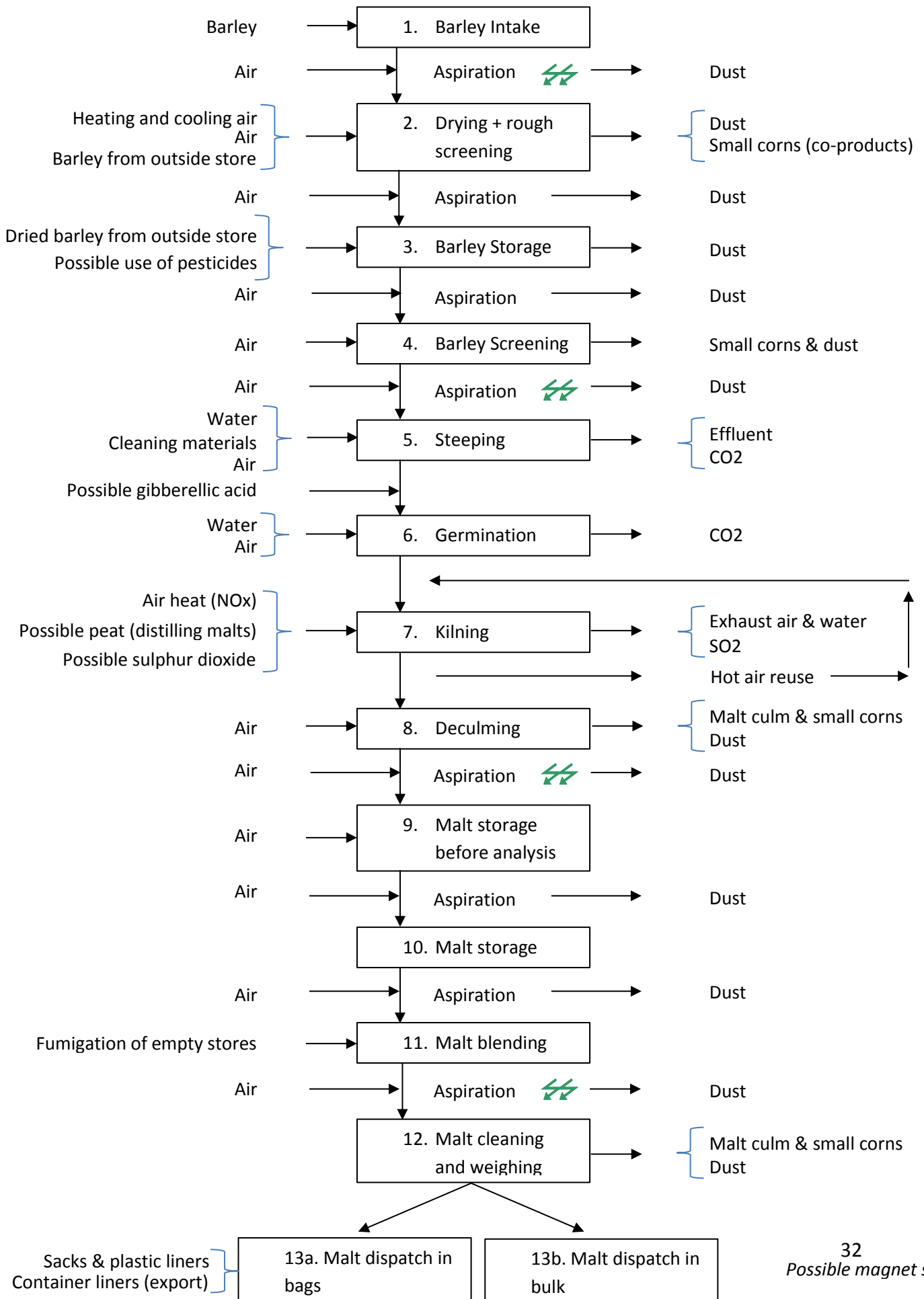

**7. MALT MANUFACTURE – HAZARDS AND RISK RATINGS (See 6 to link “Ref” to Process Stage)**

Process stage	Ref	Hazard and potential causes	Hazard type	Consequence	Risk rating	Control measures	Decision tree questions CCP/PRP						
							1	2	3	4	5		
<b>Inspection at intake of harvested grain</b>	<b>1a.1</b>	Mycotoxin contamination derived from mould; ergot on grain.	B2 & C1	Serious contamination can be very toxic	3X3	Assured grain, assured transport, purchase conditions and intake procedures. Look and smell	N	Y	Y			CCP	
	<b>1a.2</b>	Contamination from extraneous material ex farm/outside store.	P1 & P2	Can damage mills and cause explosions.  Could cause injury in food and confectionary grade malt	2X1	Assured grain, assured transport, purchase conditions and intake procedures. Intake grid, screening. Metal removal magnet.						Low risk rating	
	<b>1a.3</b>	Taint and odour on the grain, a cross contamination issue	C10 C7	Could affect beer quality	1X1	Assured grain, assured transport, purchase conditions and intake procedures. Look and smell						Low risk rating	
	<b>1a.4</b>	Insect contamination	B3	Can facilitate microbial infection. Mites secrete toxic substance	1X1	Assured grain, assured transport, purchase conditions and intake procedures. Visual inspection.						Low risk rating	
	<b>1a.5</b>	Contamination through use of non-approved pesticide, or excess application of agrochemical.	C3 & C4	Can be toxic to yeast and humans	3X2	Farm audits on assured grain.  Purchase conditions to BBPA Guide. Passport declaration with each load.	N	Y	Y			CCP	

Process stage	Ref	Hazard and potential causes	Hazard type	Consequence	Risk rating	Control measures	Decision tree questions CCP/PRP					
							1	2	3	4	5	
<b>Inspection at intake of stored grain</b>	<b>1b.1</b>	Mycotoxin contamination derived from storage mould; ergot on grain.	B2 & C1	Serious contamination can be very toxic	3X3	Adoption of good storage practices as outlined in prerequisite programme allied with purchase conditions and intake procedures. Moisture, look, smell.	Y					
	PRP (2.1 to 2.3)											
	<b>1b.2</b>	Contamination from extraneous material ex farm/outside store.	P1 & P2	Can damage mills and cause explosions.  Could cause injury in food and confectionary grade malt	2X1	Assured grain, assured transport, purchase conditions and intake procedures. Intake grid, screening. Metal removal magnet.						
	Low risk rating											
	<b>1b.3</b>	Taint and odour on the grain, a cross contamination issue	C10 C7	Could affect beer quality	1X1	Assured grain, assured transport, purchase conditions and intake procedures. Look and smell						
Low risk rating												
<b>1b.4</b>	Insect contamination	B3	Can facilitate microbial infection. Mites secrete toxic substance	1X1	Assured grain, assured transport, purchase conditions and intake procedures.							
Low risk rating												
<b>1b.5</b>	Contamination through use of non-approved pesticide, or excess application of agrochemical.	C3 & C4	Can be toxic to yeast and humans	3X2	Adoption of working practices as outlined in prerequisite programme allied with store audits and compliance with the BBPA Guide. Passport declaration with each load	Y						
PRP (2.1 to 2.3)												

Process stage	Ref	Hazard and potential causes	Hazard type	Consequence	Risk rating	Control measures	Decision tree questions CCP/PRP				
							1	2	3	4	5
Intake of barley	1.1	Heavy metal contamination	C6	Can effect beer quality and have long-term effect on consumers. Could accumulate in co-products	2X1	Assured grain, assured transport and purchase conditions.  Survey to monitor levels					
							Low risk rating				
Drying & rough screening	2.1	Mycotoxin formation due to extended pre-drying storage	C1	Serious contamination can be very toxic	2X1	Control pre drying storage time					
							Low risk rating				
Drying & rough screening	2.2	Fuel leak or bad combustion on direct fired drier	C7	Unpleasant, but toxicity usually low. Downstream processing lowers risk	2X1	Planned maintenance and operator vigilance.					
							Low risk rating				
Barley storage	3.1	Mycotoxin from mould formed due to poor drying/storage conditions	C1	Serious contamination can be very toxic	3X2	Low moisture level in stored barley will prevent mycotoxin production.	N	Y	Y		
							YES				
Barley storage	3.2	Insect contamination	B3	Can facilitate microbial infection. Mites secrete toxic substance	1X2	Insect detection traps.  Storage temperature checks					
							Low risk rating				

Process stage	Ref	Hazard and potential causes	Hazard type	Consequence	Risk rating	Control measures	Decision tree questions CCP/PRP					
							1	2	3	4	5	
	3.3	Salmonella contamination from vermin in storage area	B1	Can cause sickness in humans	2X1	Bird ingress prevention.  Integrated and planned pest control system						Low risk rating
	4.1	No hazards identified										
Steeping	5.1	Contaminated water supply, or incorrectly treated water.	B1 & C9	Malt contamination	2X1	Water Authority supply and Bore hole supply meets food safety requirements.  Analysis, training						Low risk rating
	5.2	Process aid application. a) incorrect chemical. b) contaminated chemical overdosing.		No risk from overdosing	2X1	Use only approved suppliers of process aids.						Low risk rating
	5.3	Glass and brittle plastic from process lighting	P2	Could cause consumer injury	1X1	Glass and brittle plastic policy and register in place.						Low risk rating

Process stage	Ref	Hazard and potential causes	Hazard type	Consequence	Risk rating	Control measures	Decision tree questions CCP/PRP									
							1	2	3	4	5					
	5.4	Cleaning materials	C9	Not likely to cause health risk	1X1	Use food grade quality. Training, effective rinsing procedures						Low risk rating				
	5.5	Glycosidic Nitriles formation in the finished malt for distilling.	C5	Can lead to elevated levels of ethyl carbamate in whisky.	3X2	Selection and use of appropriate barley variety	N	Y	N	Y	N	CCP				
Germination	6.1	Microbiological	B2 & C1	Serious contamination can be toxic	3X1	Correctly dried and stored barley. Regular, documented plant cleaning	Y					PRP (2.1 to 2.3)				
	6.2	Glass and brittle plastic from process lighting	P2	Could cause consumer injury	2X1	Glass and brittle plastic policy and register in place.						Low risk rating				
	6.3	Foreign objects dropping into germinating malt from plant or operators	P1 & P2	Not likely to cause consumer injury	1X1	Jewellery policy, magnets and malt screening						Low risk rating				
	6.4	Cleaning materials	C9	Not likely to cause health risk	1X1	Assessment via COSHH Training						Low risk rating				

Process stage	Ref	Hazard and potential causes	Hazard type	Consequence	Risk rating	Control measures	Decision tree questions CCP/PRP				
							1	2	3	4	5
Indirect fired kilning	7.1	NDMA formation during kilning	C2	Can be toxic and carcinogenic	3X2	Analyse malt. Low risks with indirect firing by design. Environmental NOX should be taken into account. SO2 can be added at a rate sufficient to control NDMA below critical level	Y				
							PRP (2.1 to 2.3)				
Direct fired kilning	7.2	NDMA formation during kilning	C2	Can be toxic and carcinogenic	3X3	Analyse malt. SO2 added at a rate sufficient to control NDMA below critical level	N	Y	Y		
							CCP				
Direct fired kilning	7.3	Fuel leak or bad combustion on direct fired kiln	C7	Unpleasant, but toxicity usually low. Downstream processing lowers risk	2X1	Planned maintenance and operator vigilance.					
							Low risk rating				
Deculm	8.1	No hazards identified									
Malt storage	9.1 & 10.1	Microbiological, from mould growth on malt during storage	C1	Serious contamination can be very toxic	2X2	Stock rotation and records.  Malt storage moisture much too low to create conditions for mycotoxin production	Y				
							PRP (2.1 to 2.3)				

Process stage	Ref	Hazard and potential causes	Hazard type	Consequence	Risk rating	Control measures	Decision tree questions CCP/PRP					
							1	2	3	4	5	
	9.2 & 10.2	Pest/vermin contamination	B3	Bird faeces can carry Salmonella, rodents can carry Weils disease.	2X1	Planned pest control system						Low risk rating
	9.3 & 10.3	Contamination by rodenticide	C3	Toxic to humans	3X1	Trained operator or contractor, controlled bait procedures.	Y					PRP (2.1 to 2.3)
Blending, screening and weighing	11.1 & 12.1	Foreign objects pick up	P1 P2	Can damage mills and cause explosions. Could cause injury in food and confectionary grade malt	2X1	Magnet metal removal. Physical screening action. Glass and Jewellery policy						Low risk rating
	11.2 & 12.2	Pest/vermin contamination	B3	Bird faeces can carry Salmonella, rodents can carry Weils disease.	2X1	Integrated and planned pest control system						Low risk rating
	11.3 & 12.3	Contamination by rodenticide	C3	Toxic to humans	3X1	Trained operator or contractor, controlled bait procedures.	Y					PRP (2.1 to 2.3)
Malt dispatch in sack	13a.1	Unsuitable sacks, unclean or previously used for non-food products	B1	Tainted product	2X1	Approved haulage contractor and sack inspection regime.						Low risk rating



Process stage	Ref	Hazard and potential causes	Hazard type	Consequence	Risk rating	Control measures	Decision tree questions CCP/PRP				
							1	2	3	4	5
Malt dispatch in bulk	13b.1	Contamination from foreign bodies/water in delivery vehicle trailer	B1 P1 P2	Good product tainted or contaminated by dirty vehicle	2X1	Approved contractor, who complies with current AIC Code of Practice for Road Haulage.					
							Low risk rating				

**8. THE CRITICAL CONTROL POINTS AND ACTION PLAN (See 6 to link “Ref” to Process Stage)**

Process stage	Ref	Hazard and potential causes	Critical limits	Monitoring system	Corrective action	Verification	Validation
<b>Inspection at intake of harvested barley</b>	1.a.1	Mycotoxin contamination derived from mould; ergot on grain.	Absence of mould and/or ergot	Sensory evaluation	Rejection of load	Sampling of barley at intake for mycotoxin analysis	HGCA Grain Storage Guide
	1.a.5	Contamination through use of non-approved pesticide, or excess application of agrochemical	a) Correctly presented pesticide passport with each load. b) Pesticide application should declare that all instructions have been followed.	a) Check passport b) Ensure any pesticide declared meets BBPA approval for type.	Rejection of load	Sampling of barley at intake for pesticide residues analysis	BBPA approved agrochemical list. Grain assurance schemes
<b>Barley storage</b>	3.1	Mycotoxin contamination derived from storage mould ( <i>Penicillium Verrucosum</i> )	Grain not to be stored at or above 18% moisture for more than 2 weeks.	Regular inspections of the grain during storage and test for moisture	Appropriate stock control  For example re-drying, barley movement or earlier planned processing	Analysis for mycotoxins	HGCA Grain Storage Guide, Section

Process stage	Ref	Hazard and potential causes	Critical limits	Monitoring system	Corrective action	Verification	Validation
Steeping	5.5	Glycosidic Nitriles formation in the finished malt for distilling	Selection of appropriate barley variety through consultation with customer	Stock records Customer specification Historic database of Glycosidic Nitriles residues in malt	Do not process incorrect variety	Analysis of final malt for Glycosidic Nitriles	Malting Barley approved lists.
Kilning	7.2	NDMA formation during kilning	a) The timing and burning of sulphur and the amount used is a function of local conditions and product**  b) The industry agreed maximum standard of 5 ppb  c) Low NOX burners	a) To ensure that all measured sulphur is burnt, visual check and recording is required  b) Plant maintained and operating in accordance with specified requirements  c) Correctly selected plant maintained and operated in accordance with specified requirements	a) Isolate batch for testing if inadequate sulphur burnt  b) and c) Isolate batch for testing if there are combustion problems	Analysis of malt for NDMA.	MAFF survey on ATNC in beer, published in Food Add. Contam., 1990, Vol 7 (5) pp 605 – 615.  BRi briefing note number 3.4 dated February 1995 on nitrosamines.  In house data held by company,

\*\* alternatively SO<sub>2</sub> gas may be injected into the kiln airflow

**9. FLOW CHART CO-PRODUCT MANUFACTURE (process stage numbers link to Ref in Sec 10)**

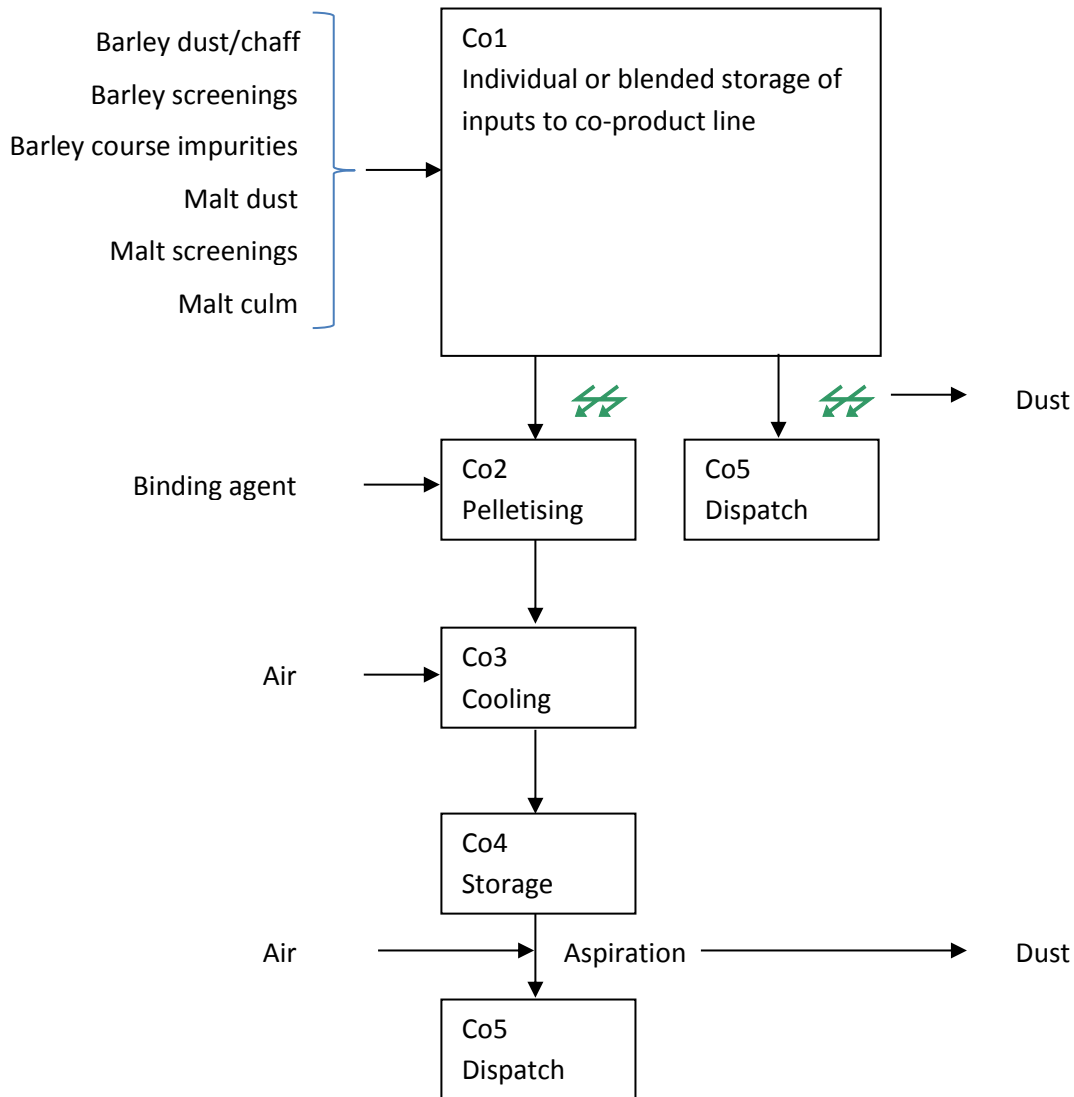

Possible magnet site 

10. CO-PRODUCT MANUFACTURE – HAZARDS AND RISK RATINGS (See 9 to link “Ref” to Process Stage)

Process stage	Ref	Hazard and potential causes	Hazard type	Consequence	Risk rating	Control measures	Decision tree questions CCP/PRP					
							1	2	3	4	5	
Co-products storage	Co1.1	Mould and potential mycotoxin formed due to poor storage conditions	B2 C1	Serious contamination can be very toxic	3X1	Low moisture level in stored barley will prevent mycotoxin production	Y					
	PRP (2.1 to 2.3)											
	Co1.2	Insect contamination	B3	Can facilitate microbial infection. Mites secrete toxic substance	1X2	Visual inspection						
Low risk rating												
Co1.3	Salmonella contamination	B1	Can cause sickness	2X1	Integrated and planned pest control system							
	Low risk rating											
Pelletising	Co2.1	Contamination from water binding agent.	B1 C9	Use of unsound water could result in impact in food chain (potentially toxic)	2X1	Use of a recognised, reliable and safe source of water. Analysis, training.						
Low risk rating												
Pellet cooling	Co3	Risk of condensation leading to water activity levels which support mould growth and mycotoxin formation.	B2 C1	Serious contamination can be very toxic	2X2	Properly cooled pellets should cause no condensation problem in store	Y					
	PRP (2.1 to 2.3)											

Process stage	Ref	Hazard and potential causes	Hazard type	Consequence	Risk rating	Control measures	Decision tree questions CCP/PRP					
							1	2	3	4	5	
Pellet storage	Co4.1	Mould and potential mycotoxin formed due to poor storage conditions	B2 C1	Serious contamination can be very toxic	2X2	Visual check to ensure no mould present, and the storage area has no moisture ingress	Y					
	PRP (2.1 to 2.3)											
	Co4.2	Pest/vermin contamination	B3	Bird faeces can carry Salmonella.	2X1	Integrated and planned pest control system						
Low risk rating												
Co-products dispatch in sacks	Co4.3	Contamination by rodenticide	C3	Toxic	2X2	Trained operator or contractor, controlled bait procedures.	Y					
	PRP (2.1 to 2.3)											
Co-products dispatch in bulk	Co5	Unsuitable sacks, unclean or previously used for non-food products	B1	Tainted product	2X1	Approved haulage contractor and sack inspection regime.						
	Low risk rating											
Co-products dispatch in bulk	Co5	Contamination from foreign bodies/water in delivery vehicle trailer	B1 P1 P2	Good product tainted or contaminated by dirty vehicle	2X1	Approved contractor, who complies with current AIC Code of Practice for Road Haulage.						
	Low risk rating											

**11. FLOW CHART SPECIALIST MALT MANUFACTURE (process stage numbers link to Ref in Sec 12)**

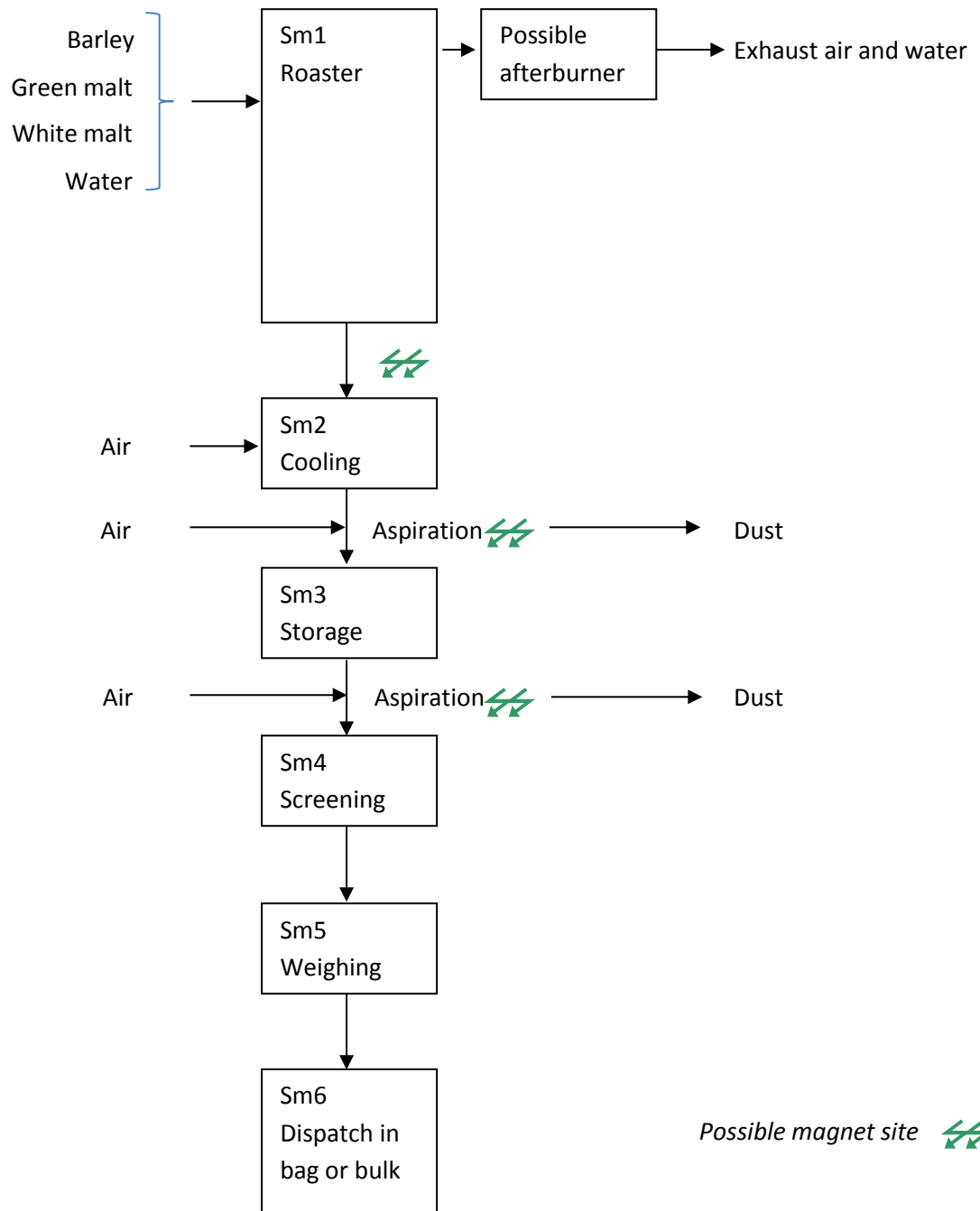

**12. SPECIALIST MALTS MANUFACTURE – HAZARDS AND RISK RATINGS (See 11 to link “Ref” to Process Stage)**

Process stage	Ref	Hazard and potential causes	Hazard type	Consequence	Risk rating	Control measures	Decision tree questions CCP/PRP				
							1	2	3	4	5
<b>Roaster</b>	<b>Sm 1.1</b>	NDMA formation from combination of amines in malt with NOX in heated air	C2	Can be toxic and carcinogenic	3x1	The elevated temperatures used in specialist malt production overcome this effect. NDMA analyses are carried out to ensure this position is maintained.					
	NOT CCP AT THIS POINT BUT LATER IN THE CHAIN										
	<b>Sm 1.2</b>	3-MCPD formation	C8	Potential carcinogen	3X3	The final colour of specialist malts is directly linked to the 3-MCPD formed. At present the technology does not exist to prevent this natural occurrence. Malt producers and malt users realise that this is an unusual situation, where the risk produced by the process can only be rectified further down the user chain by using the dilution guidelines (Section 14) devised & agreed by the industry.					
NOT CCP AT THIS POINT BUT LATER IN THE CHAIN											



Process stage	Ref	Hazard and potential causes	Hazard type	Consequence	Risk rating	Control measures	Decision tree questions CCP/PRP					
							1	2	3	4	5	
	<b>Sm 1.3</b>	Acrylamide	C8	Carcinogen	3x3	The application of heat to certain foods, including cereals, produces acrylamide. In malt the heat level needed may be used in the production of specialist malts. As with 3-MCPD the dilution factor should ensure minimum health risk						NOT CCP AT THIS POINT BUT LATER IN THE CHAIN
	<b>Sm 1.4</b>	Furans	C8	Possible carcinogen	3x2	Another substance potentially formed by the application of heat to cereals. Formation of furan is associated with formation of colour and flavour. At present its method of formation, analysis and risk assessment is not concluded						NOT CCP AT THIS POINT BUT LATER IN THE CHAIN
	<b>Sm 1.5</b>	Fuel leak or bad combustion on direct firing	C7	Unpleasant, but toxicity usually low. Downstream processing lowers risk	2X1	Planned maintenance and operator vigilance.						Low risk rating

Process stage	Ref	Hazard and potential causes	Hazard type	Consequence	Risk rating	Control measures	Decision tree questions CCP/PRP				
							1	2	3	4	5
Cooler	Sm 2	Foreign objects pick up	P1 P2	Can damage mills and cause explosions. Could cause injury in food and confectionary grade malt	2X1	Magnet metal removal Physical screening action Glass and brittle plastic and jewellery policy					
							Low risk rating				
Specialist malts storage	Sm 3.1	Microbiological, from mould growth on malt during storage	C1	Serious contamination can be very toxic	2X2	Stock rotation and records. Malt storage moisture much too low for mycotoxin production	Y				
							PRP (2.1 to 2.3)				
	Sm 3.2	Pest/vermin contamination	B3	Bird faeces can carry Salmonella; rodents can carry Weil's disease.	2X1	Integrated and planned pest control system					
						Low risk rating					
Sm 3.3	Contamination by rodenticide	C3	Toxic to humans	3X1	Trained operator or contractor, controlled bait procedures.	Y					
						PRP (2.1 to 2.3)					
Specialist malts screening	Sm 4.1 and Sm 5.1	Foreign objects pick up	P1	Can damage mills and cause explosions.	2X1	Magnet metal removal Physical screening action Glass and brittle plastic and Jewellery policy					
			P2	Could cause injury in food and confectionary grade malt			Low risk rating				

Process stage	Ref	Hazard and potential causes	Hazard type	Consequence	Risk rating	Control measures	Decision tree questions CCP/PRP					
							1	2	3	4	5	
Dispatch	Sm 4.2 and Sm 5.2	Pest/vermin contamination	B3	Bird faeces can carry Salmonella; rodents can carry Weil's disease.	2X1	Integrated and planned pest control system						Low risk rating
	Sm 4.3 and Sm 5.3	Contamination by rodenticide	C3	Toxic to humans	3X1	Trained operator or contractor, controlled bait procedures.	Y					PRP (2.1 to 2.3)
	Sm 6	Unsuitable or unclean sacks- Reusable sacks that have erroneously used for non-food products. Unclean delivery vehicle	B1	Tainted product	2X1	Approved haulage contractor, who complies with AIC Code of Practice for Road Haulage. Sack inspection regime						Low risk rating

### 13. THE ADDITIONAL CRITICAL ISSUE ACTION PLAN FOR SPECIALIST MALTS

Process stage	Ref	Hazard and potential causes	Critical effect	Monitoring system	Corrective action
<b>Roasting</b>	<b>Sm 1.2</b>	<b>3-MCPD formation during roasting</b> The application of high temperature to cereals produces 3-MCPD. In malts this occurs when temperatures exceed kilning profiles, which is the whole range of roasting regimes used for specialist malts above 25 EBC colour and roasted barley.	The higher the final desired specialist malt colour, the higher the 3-MCPD in the finished malt	‘Operator expertise’ is the only monitoring system available during specialist malt production.	Avoid excessive application of high temperature.  The corrective action can only be undertaken by the food producer who must undertake to use the product in their recipes in the dilution factor laid down in the industry guideline as shown below.  <b>(See Section 14 below)</b>
	<b>Sm 1.3</b>	<b>Acrylamide formation during roasting</b> Acrylamide can be formed in cereals during the manufacture of speciality malts and roasted products where high temperature kilning is used. May cause cancer in humans – as a precaution should minimise levels as much as possible without adversely affecting product quality (colour/flavour)	Acrylamide may be present at elevated levels in the range 50-500EBC colour units.	‘Operator expertise’ is the only monitoring system available during specialist malt production.	Careful selection of the speciality malt can significantly impact the final levels of acrylamide in final product.  Acrylamide is highly volatile and is consequently reduced during high temperature kilning for roasted speciality malts. Levels peak in the range 50-500EBC with cara and crystal types.  Application and use of speciality malts are such that levels in final product are significantly reduced by recipe dilution.

Process stage	Ref	Hazard and potential causes	Critical effect	Monitoring system	Corrective action
	<b>Sm 1.4</b>	<p><b>Furan formation during roasting</b>  Furan can be formed in cereals during the manufacture of speciality malts and roasted products where high temperature kilning is used. May cause cancer in humans – as a precaution should minimise levels as much as possible without adversely affecting product quality (colour/flavour)</p>	<p>Initial work has detected furan levels from 50µg/kg in pale malts to 3500µg/kg in malts &gt;1000EBC colour.</p>	<p>‘Operator expertise’ is the only monitoring system available during specialist malt production.</p>	<p>Avoid excessive application of high temperature.</p> <p>Furan is highly volatile and some is expected to be lost during high temperature kilning.</p> <p>Most of the furan potentially present in speciality malts is lost during brewing. Beers contain low levels of furan.</p>

#### 14. THE BLRA/AMPM/MAGB GUIDELINES TO PREVENT HEAT RELATED TOXINS BECOMING A PROBLEM IN BEER AND OTHER FOOD

Material	Typical colour range (EBC Colour Units)	3-MCPD (µg/kg)	Acrylamide (µg/kg)	NDMA (µg/kg)*	Furan (µg/kg)	Typical dilution in foodstuffs
'White' malted barley (lager, ale, mild ale, distilling malt)	<9	<10	<15	<0.5	<28	1:10 (i.e. 1kg malt per 10 kg product)
Munich malt	10-25			<0.5	<110	1:50
Melanoidin malt	30-60			<0.5	100-220	1:50
Cara malt	20-50	<30		<0.5	110-320	1:50
Crystal malt	50-600	10-200	920-1290	<0.5	220-1100	1:50
Amber malt	30-200	10-200	500-1100	<0.5	300-900	1:100
Roasted malts (brown, chocolate, black)	300-1,400	50-500	20-65	<0.5	2300-4100	1:100
Roasted barley	900-1,400	100-500	5-20	<0.5	2800-5500	1:100

#### Notes

\*NDMA all product types comply with industry agreed guidelines of max 5 µg/kg with processes well controlled and values typically less than 0.5 µg/kg

**15. EXTRACT FROM BBPA/BRI BRIEFING NOTE ON – ALLERGENIC REACTIONS**

- 15.1. A small number of people suffer adverse reactions to certain foods and food components. This is termed a food allergy.
- 15.2. These foods are perfectly harmless to the rest of the population.
- 15.3. Most food allergies are caused by staple foods, such as cereals, milk, eggs and fish.
- 15.4. Coeliac disease affects about 1 person in 1000 in the UK. Such individuals cannot properly digest the protein (gluten) in certain cereals, such as wheat and barley. Beer is made from malted barley, and it is therefore possible that some coeliac sufferers could be adversely affected by drinking beer. However, most of the protein is removed during brewing, so the amount of protein in beer, which could affect coeliac sufferers, is very low.
- 15.5. Some individuals (about 1% of the population) are sensitive to sulphites.
- 15.6. Sulphites are used in many foods as preservatives, at much higher levels than are found in beer. For example the level of sulphite in many wines is 10 times that in beer
- 15.7. Small amounts of sulphite may be used in beer to protect the flavour
- 15.8. The EU controls use of sulphite in foods.
- 15.9. Future legislation in the EU, currently in draft form, will require all foods made from or containing certain common allergens, to be labelled.

END

**MAGB HACCP GUIDE FOR MALTING**

**CHANGES LOG**

Summary of change	Affecting page numbers	Reason for change	Authorised by	Revision number	Date